

# Global Network

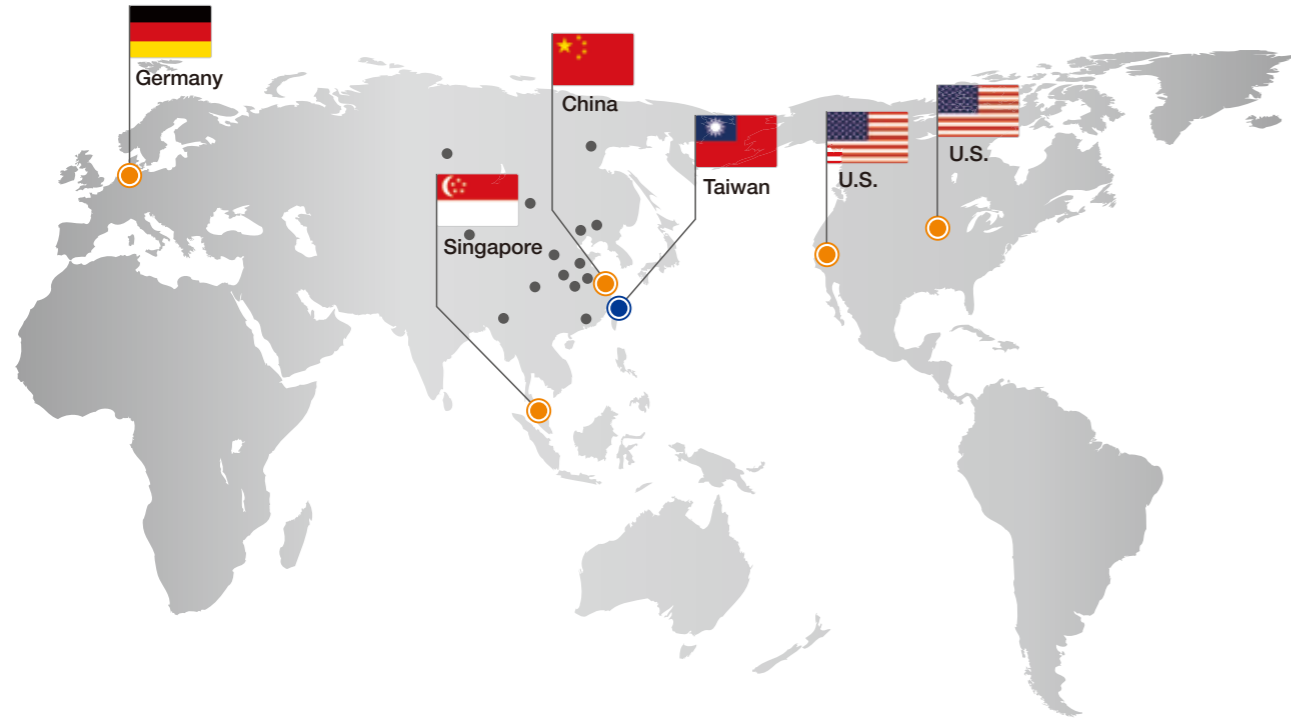

## Asia

● **Taiwan**  
 FINETEK CO., LTD. - Taipei Head Quarter  
 No.16, Tzuchiang St., Tucheng Industrial Park  
 New Taipei City 236, Taiwan  
 TEL: 886-2-2269-6789  
 FAX: 886-2-2268-6682  
 EMAIL: info@fine-tek.com

FINETEK CO., LTD. - I-Lan Factory  
 TEL: 886-3-990-9669  
 FAX: 886-3-9909659

FINETEK CO., LTD. - Taichung Brance  
 TEL: 886-4-2337-0825  
 FAX: 886-4-2337-0836

FINETEK CO., LTD. - Kaohsiung Branch  
 TEL: 886-7-333-6968  
 FAX: 886-7-536-8758

● **China**  
 FINE AUTOMATION CO., LTD. - Shanghai Factory  
 No.451 DuHui Rd, MinHang District, Shanghai,  
 China 201109  
 TEL: 86-21-6490-7260  
 FAX: 86-21-6490-7276  
 EMAIL: info.sh@fine-tek.com

● **Singapore**  
 FINETEK PTE LTD. - Singapore Office  
 No. 60 Kaki Bukit Place, #07-06 Eunos  
 Techpark 2 Lobby B, Singapore 415979  
 TEL: 65-6452-6340  
 FAX: 65-6734-1878  
 EMAIL: info.sg@fine-tek.com

## North America

● **California, U.S.**  
 APLUS FINETEK SENSOR INC. - US Office  
 355 S. Lemon Ave, Suite D, Walnut,  
 CA 91789  
 TEL: 1 909 598 2488  
 FAX: 1 909 598 3188  
 EMAIL: info@aplusfine.com

● **Illinois, U.S.**  
 APLUS FINETEK SENSOR INC.  
 TEL: 1 815 632-3132  
 FAX: 1 815 716 8464  
 EMAIL: info@aplusfine.com

## Europe

● **Germany**  
 FineTek GmbH - Germany Office  
 Frankfurter Str. 62, OG D-65428  
 Ruesselsheim, Germany  
 TEL: +49-(0)6142-17608-0  
 FAX: +49-(0)6142-17608-20  
 EMAIL: info@fine-tek.de



Distributor:

08-EST-B0-CP, 05/18/2015



## EST Grain Silo Temperature & Level Monitoring System



www.fine-tek.com



# System Introduction



Temperature is a key factor for maintaining grain quality in a grain storage system. When the grain has suffered from deterioration, corrosion or pest and disease damage, the temperature is increased inevitably. If precise temperature information of the grain can be mastered, an air conditioning system can be more efficiently controlled to achieve high efficient energy management. For silo management, an EST system can measure grain temperature in silo and measure stored grain level synchronously, thereby not only instantly tracking and recording grain conditions, recording historical records, but also providing optimal grain storage quality monitoring.

The EST can be matched with the HubLink hub series, and employs an RS485 communication interface to transmit information to a central control room or a human-machine interface via wire or wirelessly. The EST is matched with MMS-TLA silo information and integrated with monitoring software, so that a user can easily monitor dual information, both the temperature and grain level in the silo, through a remote computer, thereby performing grain storage management with the utmost convenience and efficiency.

# System Architecture

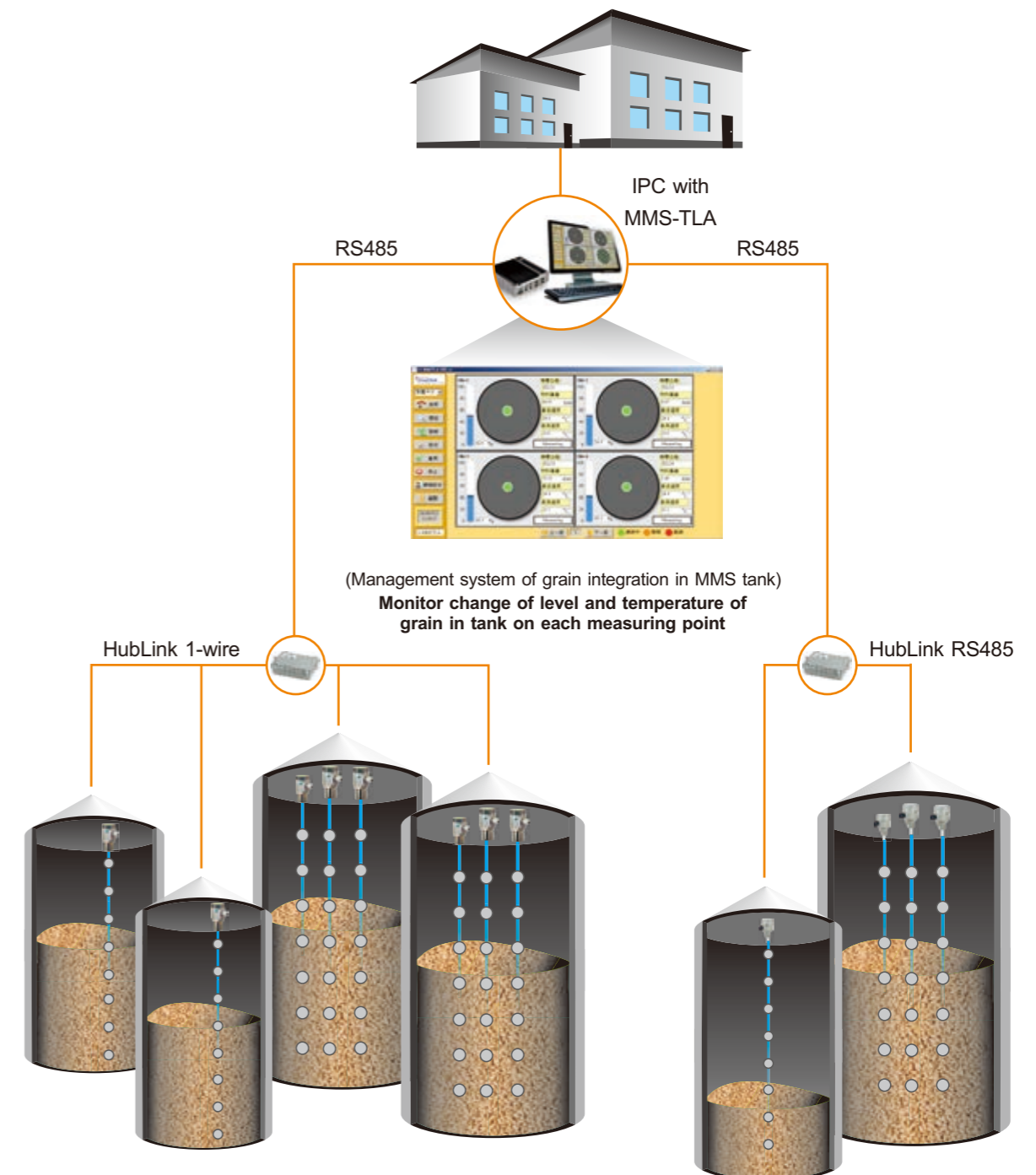

# EST110

## multi-point temperature sensor

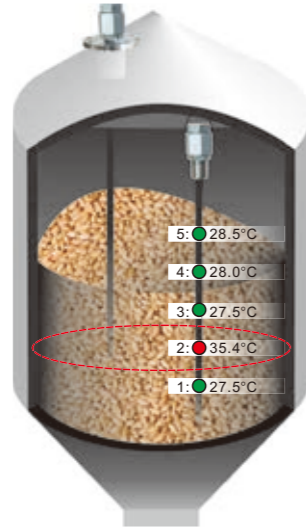

### System Introduction

EST110 multi-point temperature sensor wire can measure temperature of grain in different positions of the silo in real time, to record condition of the grain and provide you the optimal monitoring of grain storage quality. Relative to the traditional silo, manual temperature measurement is time-consuming and arduous. The temperature measured by EST110 is digital signal, which can output RS485 communication mode through matching with HubLink 1-wire to transmit information to the central control room or human-machine interface. The user can easily know the grain temperature in the silo only from the remote end and conduct the most efficient grain storage management.

### Features

- Reinforced steel cable design can effectively resist the impact of grain and prolong service life of the product.
- Provide multi-point temperature measurement to help managers cope with food more swiftly.
- Detect whether there is fungus produced or activities of insects, to maintain food quality.
- Provide real-time monitoring of silo temperature for practitioners in food, fodder and grain, to help long-term storage.
- Prevent qualitative change of grain in the silo and fire disaster due to smolder.
- Temperature measurement position can be customized according to customer's requirements, which can be hung outside or built in the silo.

### Specifications

Measurement range	-10~85°C
Resolution	0.1 °C
Accuracy	± 0.5 °C
LengthMax.	Max. 30 m
Quantity of sensors	Max. 30 PCS
Position of sensors	One sensor is built in every meter
Cable material	Coated with PVC, inner ring is copper wire (Standard)
Tensile load	5000 Kgf
IP rating	IP67

### Dimension

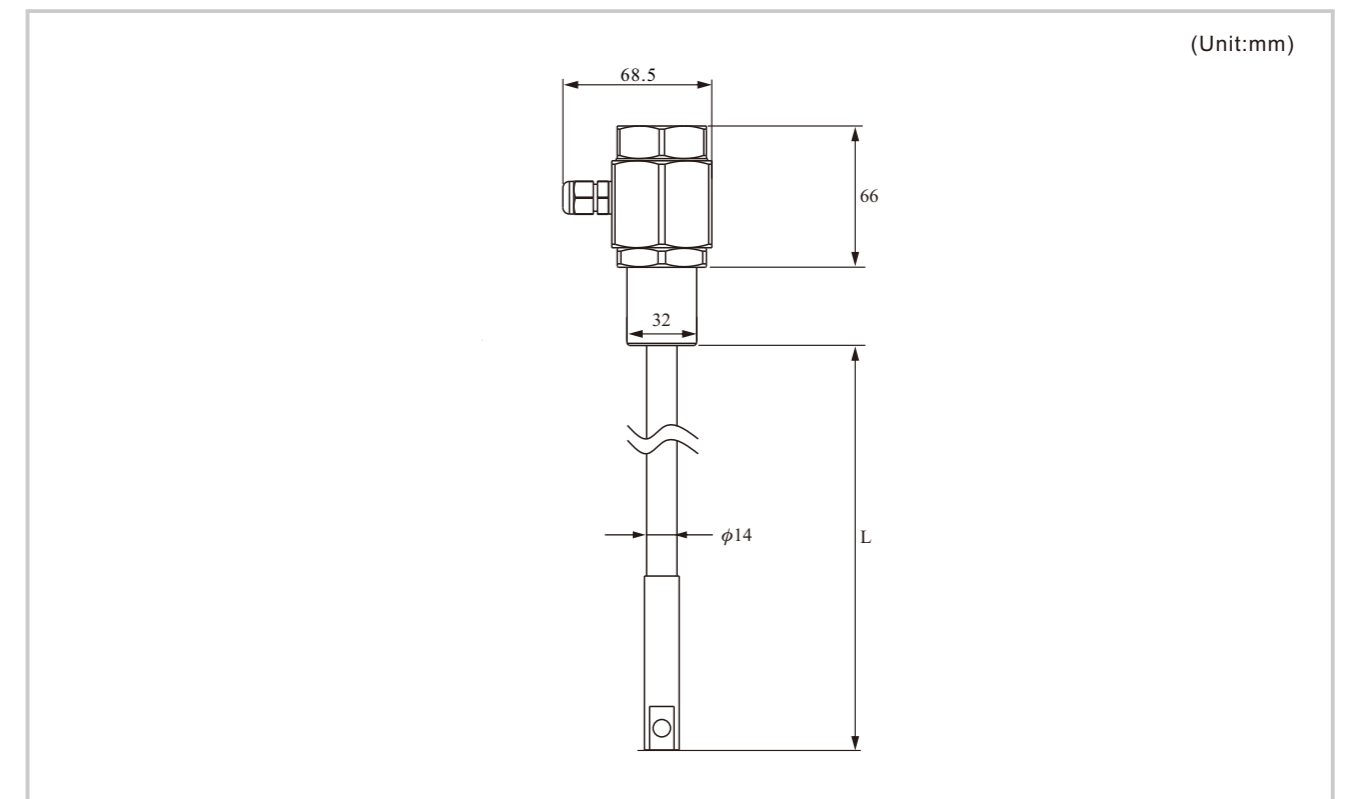

# EST120 2 in 1 grain temperature & level monitoring transmitter

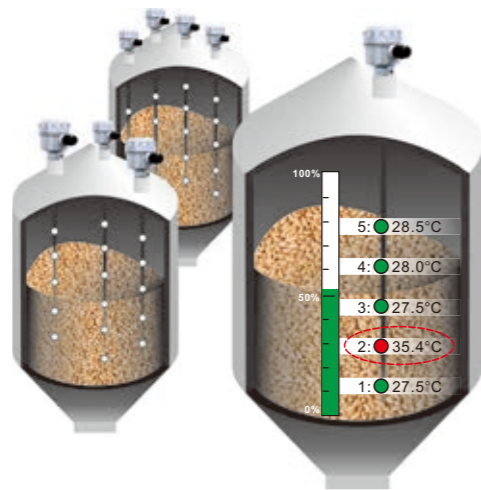

## Introduction

For silo management, users must install temperature sensing wire and grain level sensor separately in the past to get the information of temperature and grain level. EST120 two-in-one silo temperature and grain level meter can synchronously measure grain temperature and level in the silo, to track and record grain condition, so as to provide you the optimal grain storage quality monitoring. EST120 adopts the RS485 communication interface, to transmit information to the central control room or human-machine interface. Users can monitor dual information of grain temperature and level in the silo from the far end, to conduct the most convenient and efficient grain storage management.

## Features

- Unique in the industry, EST120 transmitter integrated with simultaneous monitoring of grain level and temperature.
- Steel cable design can effectively resist the impact of grain and prolong service life of the product.
- Provide real-time multipoint temperature measurement to help managers cope with food more swiftly.
- Detect whether there is fungus produced or there are activities of insects, to maintain food quality and facilitate long-term storage.
- Prevent qualitative change of grain in the silo and fire disaster due to smolder.
- Temperature measurement can be customized according to customer's requirements.
- Any two points of EST120 are in simple calibration mode of grain level.
- The product uses open main current communication interface RS485. The system user can install the device on any system having the communication interface.

## Specifications

Power input	9 ~ 30 Vdc	Non-linearity of grain level	± 1 % FS
Measurement range	-10~85 °C	Output interface	RS485; Baud Rate:9600~57600 bps
Resolution	0.1 °C	Material of junction box	Aluminum alloy (ADC-12)
Accuracy	±0.5 °C	Outgoing cable diameter	φ5.5~11.2 mm
Length	Max.30 m	Cable material	Coated with PVC, inner ring is copper wire
Quantity of sensors	Max.30 PCS	Tensile load	5000 Kgf
Position of sensor	One sensor is built in every meter	IP rating	IP 67
Sampling speed	Grain level measurement: ≤1sec Temperature measurement: ≤1sec/node		

## Dimension

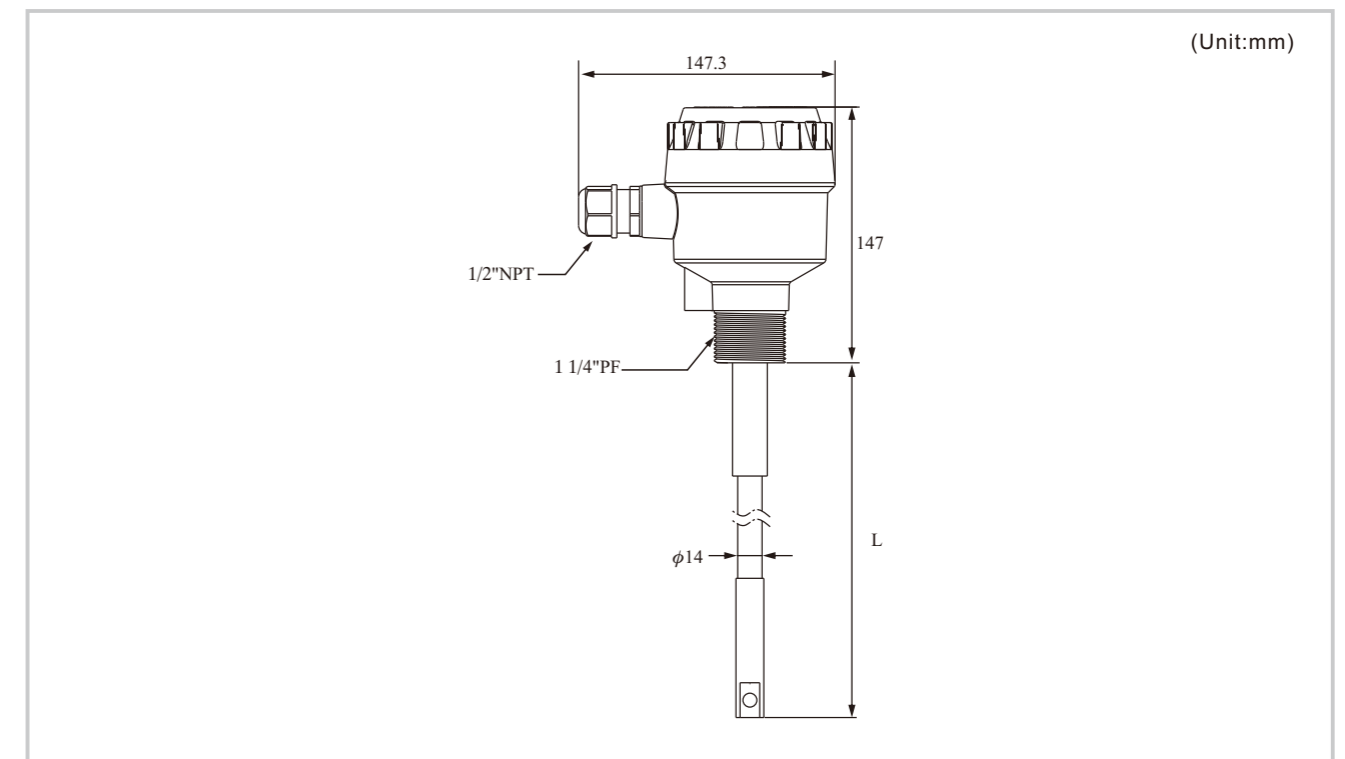

# MMS-TLA

## Materials Management System



### Software (MMS-TLA)

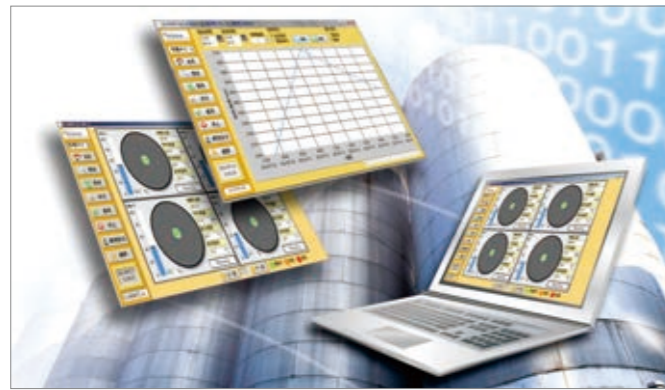

#### System Requirements

- Central processing unit (CPU) P4 1GHz above
- Memory RAM 512MB above
- Operating system Microsoft Windows 2000 above
- At least 1GB idle hardware space for database
- RS232 or USB

### Introduction

MMS-TLA intelligent grain silo temperature and level management system is a set of PC software, which can replace measurement and record manually and operating method is through configuration of electricity meter and switch. It can be widely applied to industries such as rice milling, flour, fodder, food, low temperature unhulled rice and grain crop as well as grain level environment that needs measurement of multi-point temperature. It is applicable to temperature and grain level detection in tank and barrel of general power, particle and block. MMS-TLA can monitor temperature change of the silo all the time, to prevent abnormal temperature, so as to avoid damage to the grain. It can also effectively manage entry, stock and sales of grain, to reduce operating cost, so as to increase profit and improve customers' competitiveness.

### Features

- Set Item: Tank number, tank name, device number, device model, HubLink 1-Wire general setting, grain high level alarm, grain low level alarm, high temperature alarm, low temperature alarm, series port setting, connection timeout setting, selection of multiple tank types and related parameters corresponding to sizes, alarm sending mode, alarm information receiving mode and account setting and SMTP email server setting, etc.
- Display Item: Tank name, grain percentage, grain weight, minimum temperature, maximum temperature, current temperature of each measuring point of a sensing device, temperature change of a certain sensing device's certain measuring point on that day and history information review, etc.
- Alarm Item: Grain high/low level alarm, high/low temperature alarm and connection timeout, etc.
- Report Output: History information is transformed to text or Excel format.
- Alarm Mode: Display it on the screen on the spot and utilize e-mail to transmit alarm information to preset receivers through regional Intranet or Internet.
- Account Setting: Set the account for rights of Supervisor or Operator.

### IPC (Industrial PC)



#### Dimension

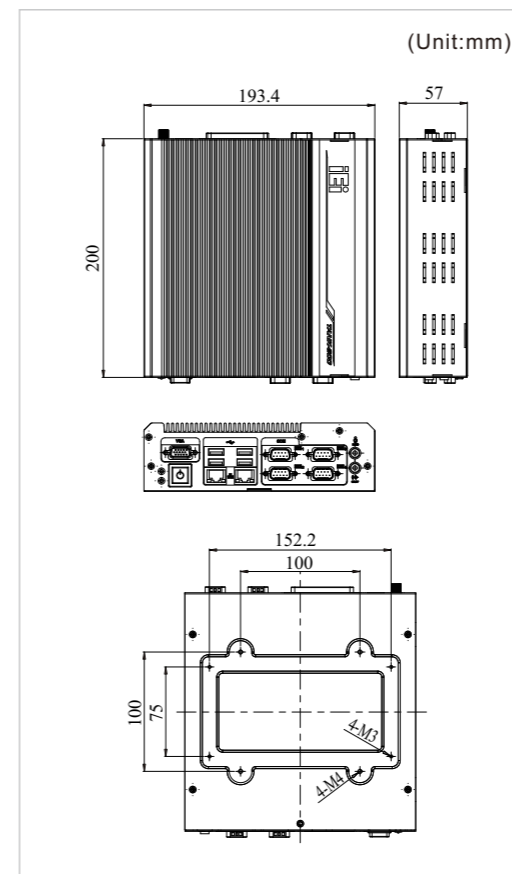

### Features

- Intel® Dual Core D2550 1.86 GHz processor
- 8 COM model: 6 x RS-232, 2 x RS-232/422/485
- 6 x USB 2.0
- Dual PCIe GbE LAN for high-speed network applications

### Specifications

Model Name	TANK-600-D2550	
Chassis	Color	Black C + Silver
	Dimensions (WxDxH)	193.4 x 200 x 57 mm
	System Fan	Fanless
	Chassis Construction	Aluminum alloy
Motherboard	CPU	Intel® D2550 1.86 GHz dual-core processor
	Chipset	Intel® NM10
	System Memory	On-board DDR3 4GB
Storage	Hard Drive	1 x 2.5" SATA HDD Bay
	USB 2.0	6
I/O interfaces	Ethernet	2 x RJ-45 Realtek 8111E GbE LAN
	RS-232	6 COM: 6 x DB-9 16 COM: 14 x RS-232 by DB-78
	RS-422/485	2 x RS-232/422/485 by DB-9
	Display	1 x VGA
	Resolution	VGA: Up to 2048 x 1536 @ 75Hz
	Audio	1 x Line-out, 1 x Mic-in
Expansions	PCIe Mini	1 x Full Size (Support mSATA) 1 x Half size
	Power Input	DC Jack : 9~36V DC
Power	Power Consumption	12V@2.2A (Intel® Atom™ D2550 with 4GB DDR3 memory)
	Mounting	VESA 100, DIN-Rail
Reliability	Operating Temperature	-20°C ~70°C with air flow (SSD), 5% ~ 95%, non-condensing
	Operating Shock	Half-sine wave shock 5G, 11ms, 3 shocks per axis
	Operating Vibration	MIL-STD-810F 514.5C-2 (with SSD)
	Weight (Net/Gross)	2.2 Kg / 3 Kg
OS	Safety / EMC	CE/FCC
	Supported OS	Microsoft® Windows®7

# HubLink 1-wire / HubLink RS485



## HubLink 1-wire

(Unit:mm)

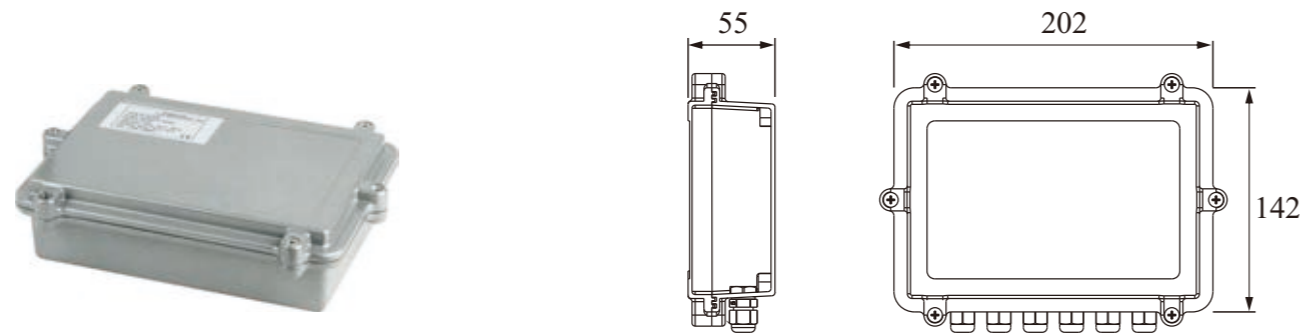

### Introduction

It extends and connects to the sensor through wired way, which can connect 4 sets of EST110 1-Wire communication modes. Each sensor has an independent connection, which can prevent the whole system from crashing due to a particular equipment failure, so as to make users capable of maintaining multiple equipment more easily. 1-wire digital signal can be transformed to RS485 to make MMS-TLA silo temperature and grain level management system or PLC read and use.

### Specifications

Supply voltage	10~30Vdc
Ambient temperature	-40~80°C
Connection port	Max.4
Housing	Aluminum alloy (ADC-12)
Communication interface	RS-485
Sensor	1-Wire digital temperature sensor
RS-485 baud rate	9600~115200
IP rating	IP67

## HubLink RS485

(Unit:mm)

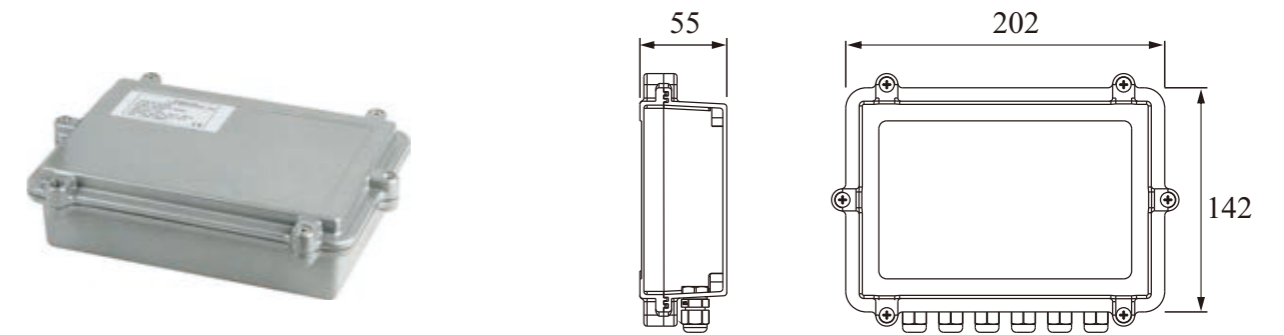

### Introduction

It integrates 4 sets of signals with RS485 communication mode to make wiring more convenient and clear. Each port is independent, which can prevent the whole system from crashing due to a particular equipment failure, to make users capable of maintaining multiple equipments more easily. 4 sets of 4-wire type connection ports also supply 24VDC power for external device.

### Specifications

Power input	10~30Vdc
Current input	2A
Power output	10~30Vdc
Current output	400 mA / CH (under power input and current of 2A)
Output	RS-485
Input	Four sets of RS-485 (each set is independent and isolated)
Baud rate	1200~57600
Working temperature	-40~80°C
Electrostatic protection	IEC61000-4-2 ESD 8kV Air, 4kV contact
IP rating	IP67

# Application Example



## Case 1: EST110

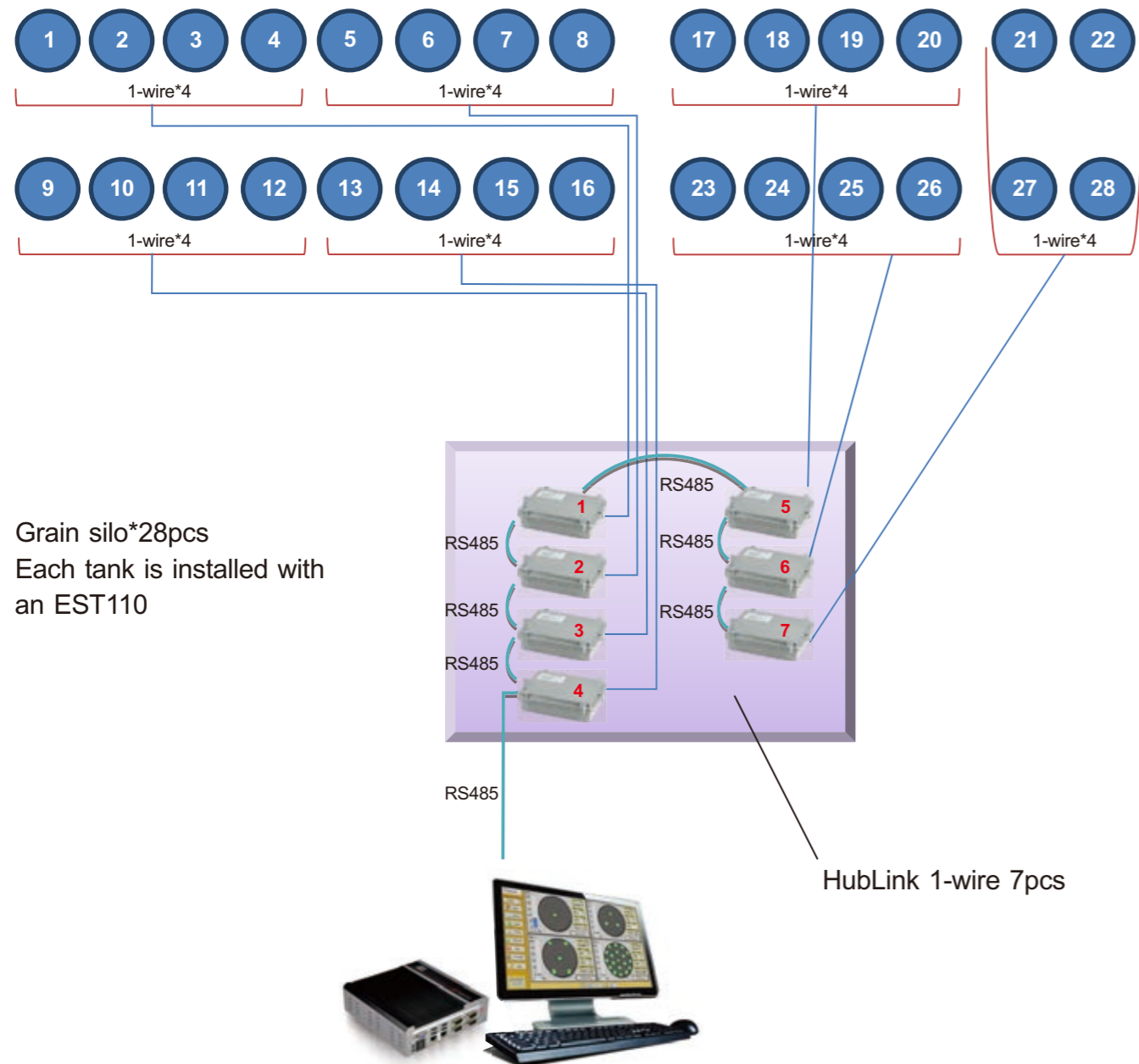

## Case 2: EST120

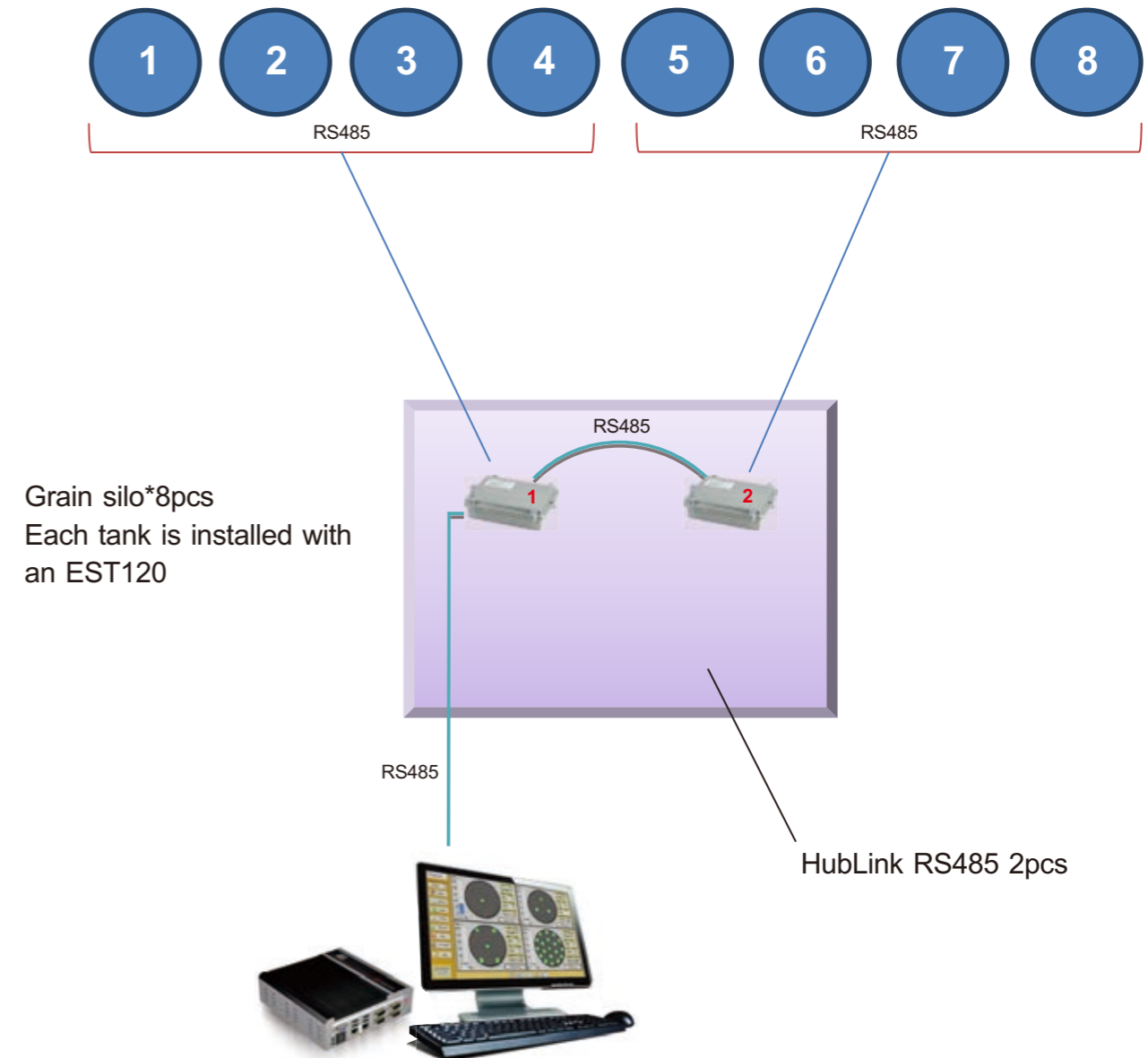

# Application Example

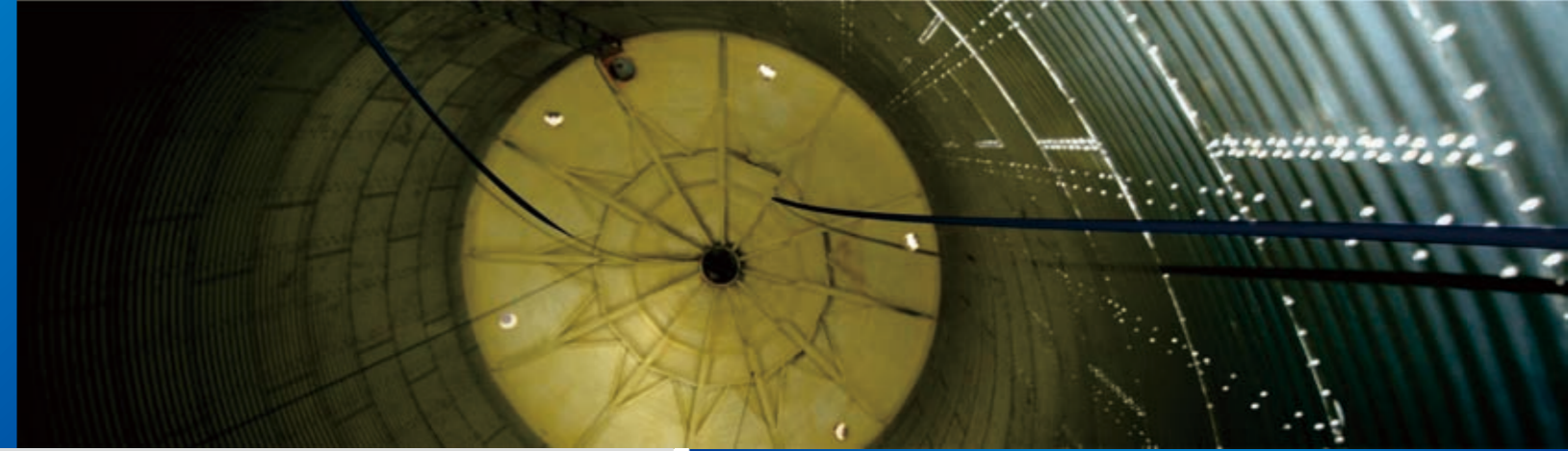

## Case 3: EST110+EST120

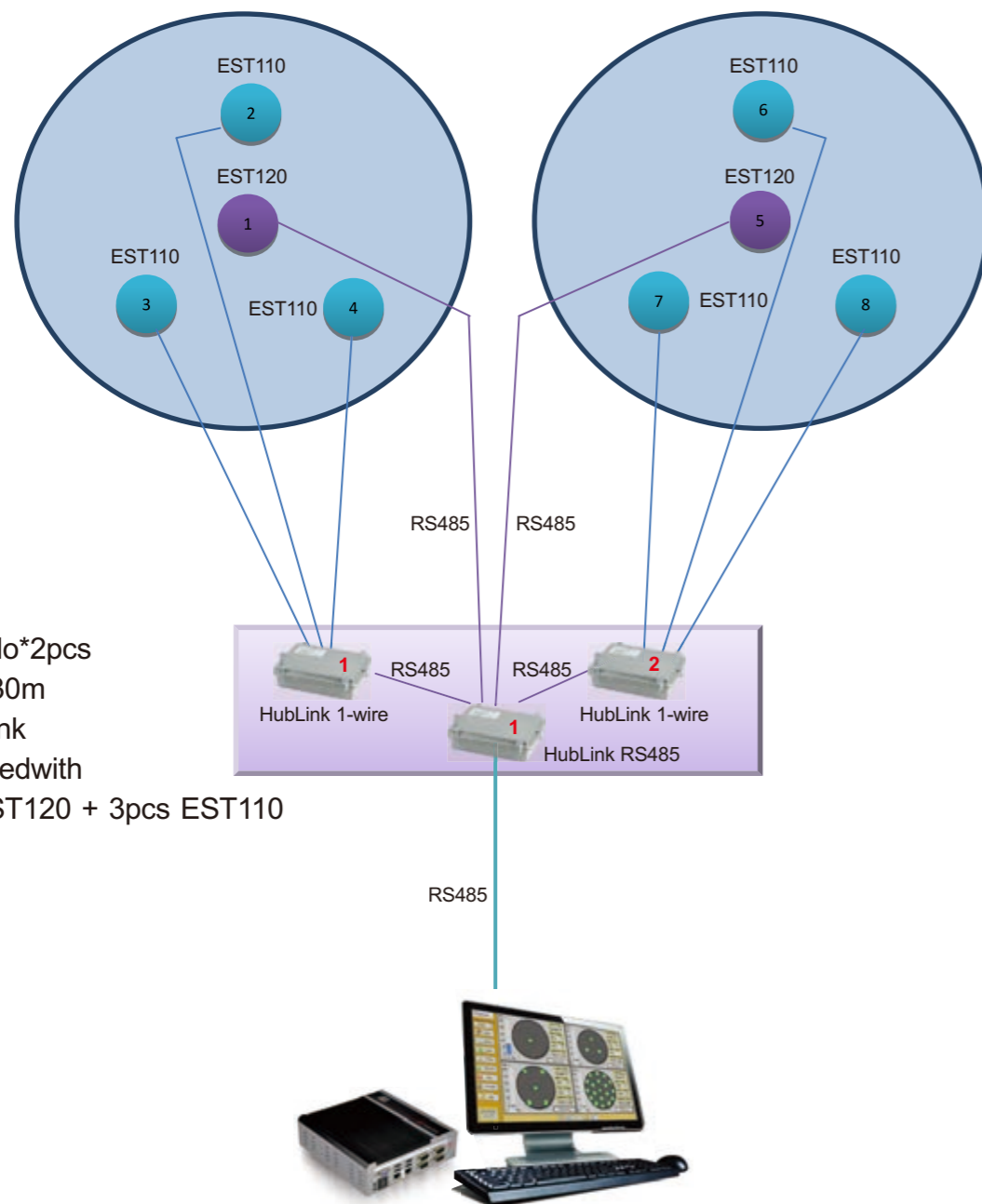

## Successful stories



▲ EST120



▲ HubLink RS485



▲ HubLink 1-wire



▲ EST120



▲ EST110



# Order Information



## EST110 multi-point temperature sensor

EST110-0030-10-30

Connection

	Size		Specification
Flange	E: 1-1/2"	I: 4"	M: 5kg/cm <sup>2</sup>
	F: 2"	J: 5"	N: 10kg/cm <sup>2</sup>
	G: 2-1/2"	K: 6"	O: 150Lbs
	H: 3"		P: 300Lbs

SS: Special connection  
 00: No flange  
 88: Hanging hook (ETB-0030)  
 99: Adjustable rotation angle mechanism (ETB-0040)

Length (Unit:m)

- 01: 1m(min.)
- 02: 2m
- ⋮
- 30: 30m(max.)

Sensor interval

- 05: One sensor every 0.5m
- 10: One sensor every 1m (std.)
- 15: One sensor every 1.5m
- 20: One sensor every 2.0m
- ⋮
- 95: One sensor every 9.5m (max.)

Sensor amount

- 01: 1PCS
- 02: 2PCS
- ⋮
- 30: 30PCS(max.)

## EST120 2 in 1 grain temperature & level monitoring transmitter

EST120-FM30-10-30

Connection

	Size		Specification
Flange	E: 1-1/2"	I: 4"	M: 5kg/cm <sup>2</sup>
	F: 2"	J: 5"	N: 10kg/cm <sup>2</sup>
	G: 2-1/2"	K: 6"	O: 150Lbs
	H: 3"		P: 300Lbs
Screw	3: 1-1/4"		R: PF(G) U: NPT

SS: Special connection  
 88: Hanging hook (ETB-0031)  
 99: Adjustable rotation angle mechanism (ETB-0041)

Length (Unit:m)

- 01: 1m(min.)
- 02: 2m
- ⋮
- 30: 30m(max.)

Sensor interval

- 05: One sensor every 0.5m
- 10: One sensor every 1m (std.)
- 15: One sensor every 1.5m
- 20: One sensor every 2.0m
- ⋮
- 95: One sensor every 9.5m (max.)

Sensor amount

- 01: 1PCS
- 02: 2PCS
- ⋮
- 30: 30PCS(max.)

# Order Information

## IPC contains MMS-TLA

- ETB-0001** IPC (traditional Chinese WINXP)
  - + MMS-TLA
  - + RS485-USB converter (YTXPUSB485-T)
- ETB-0003** IPC(English WINXP)
  - + MMS-TLA
  - + RS485-USB converter (YTXPUSB485-T)
- ETB-0005** IPC(simplified Chinese WINXP)
  - + MMS-TLA
  - + RS485-USB converter (YTXPUSB485-T)

## HubLink

- JMH104-M** HubLink 1-wire
- JMH101-M** HubLink RS485



## Accessories

